



Independent State of Papua New Guinea

GENERAL ORDER NO. 3

RECRUITMENT, SELECTION, APPOINTMENT AND STAFF REPORTING

Being a General Order to effect recruitment and selection of officers in the Public Service. This General Order covers recruitment, selection, transfer, promotion, staff reporting and all other recruitment and selection matters, including the maintenance of proper establishment and staff on strength records in the Government's Human Resource & Payroll Management System.

Made under the:-

Public Services (Management) Act 1995 (as amended)

I, **John M Kali OBE**, Departmental Head of the Department of Personnel Management, by virtue of the powers conferred by Section 70 of the *Public Services (Management) Act 1995*, and all other powers me enabling, hereby issue General Order No 3, as part of the Fourth Edition of General Orders effective on and from 1st January 2012 and to remain in force until further notice.

JOHN M KALI OBE
Secretary

GENERAL ORDER NO.3

RECRUITMENT, SELECTION, APPOINTMENT AND STAFF REPORTING

TABLE OF CONTENTS

<u>Subject Matter</u>	<u>General Order Section</u>
General Policy Objectives	3.1 - 3.13
Procedures for Recruitment & Selection	3.14 - 3.18
Filling Vacant Positions - Staff & Cash Ceilings	3.19 - 3.22
Staff on Strength Records for Purposes of Recruitment	3.23 - 3.26
Advertisement of Vacant Positions	3.27 - 3.38
Applications for Vacant Positions	3.39 - 3.42
The Selection Process	3.43 - 3.46
Composition of Selection Committees	3.47 - 3.52
Receiving and Acknowledging Applications	3.53 - 3.54
Short Listing Applicants	3.55 - 3.59
Reference Checking	3.60 - 3.64
Procedures for Conducting Selection Hearings	3.65 - 3.81
Pre Selection Decisions and Reporting	3.82 - 3.85
Notification of the Selection Committees Decisions	3.86 - 3.101
The National Gazette – Printing and Distribution	3.102 - 3.103
Engagement of External Recruitment Agencies	3.104
Role of Human Resource Manager	3.105
Guidelines for Maintaining Staff Records	3.106 - 3.127
<hr/>	
Selection Process	Schedule 3.1
Advertising in Government Gazette (Optional)	Form RS3.1
Application for Vacant Position	Form RS3.2
Selection Committee Oath of Office	Form RS3.3
Acknowledgement of Individual Application	Form RS3.4
Notification to Unsuccessful Candidate	Form RS3.5
Register of Applicants	Form RS3.6
Shortlist Applicant Profile	Form RS3.7
Pre selection and Short listing Report	Form RS3.7(A)
Applicant Ratings Summary	Form RS3.8

Rank Preference of Candidates	Form RS3.9
Selection Decision Form	Form RS3.10
Notification to Successful Applicant	Form RS3.11
Promotion/Transfer of Successful Applicant	Form RS3.12
Conditional Offer of Employment	Form RS3.13
Approval to Appoint a Probationary Officer	Form RS3.14
Notification of Appointment to the Public Service	Form RS3.15
Final Selection Report	Form RS3.16
Establishment Register – Positional Occupancy	Form RS3.17
List of Unattached Officers	Form RS3.18
List of Long Term Suspended Officers	Form RS3.19

GENERAL ORDER NO.3

RECRUITMENT, SELECTION, APPOINTMENT AND STAFF REPORTING

GENERAL POLICY OBJECTIVES

- 3.1 Section 24, subsection (2)(c) of the *Public Services (Management) Act 1995*, provides that the Secretary, Department of Personnel Management has responsibility for the selection and appointment of officers, in accordance with the procedures specified in General Orders.
- 3.2 The Secretary, Department of Personnel Management has, under Section 23 of the Act, delegated all powers and responsibilities for selection and appointment to Departmental Heads and Provincial Administrators under the provisions of Section 36 of the Act and this General Order, as follows:
- (a) the selection and appointment to all positions **below** Secretary level have been delegated to Departmental Heads/Provincial Administrators, subject to this General Order; and,
 - (b) the selection and appointment of non-citizens to the Public Service shall remain the responsibility of the Secretary, Department of Personnel Management under General Order 11.
- 3.3 **The Secretary, Department of Personnel Management maintains the right to withdraw the delegations under this General Order at such time he/she has reason to believe that any selection or appointment has been effected contrary to this General Order, and to declare any such improper selection or appointment decision to be null and void.**
- 3.4 Reference to a Departmental Head includes reference to a Provincial Administrator who is a deemed Departmental Head, and reference to a Department includes reference to a Provincial Government Administration. Reference to a Departmental Head also includes an Agency Head who is accountable for staffing matters.
- 3.5 **Recruitment** means the appointing of a person to a vacant position in an establishment approved under General Order .2, in one of the following ways:
- (a) a **Probationary Officer** pursuant to this General Order and General Order 4; and,
 - (b) a **Senior Officer on contract**, pursuant to General Order 9; and,
 - (c) a **Short term contract employee** pursuant to General Order 10.
- 3.6 **Vacancies in approved establishments may be filled by recruitment of persons from outside of the Public Service, only through the arrangements described under General Order 3.5. Recruitment by any other means is illegal and subject to annulment by the Secretary, Department of Personnel Management.**

- 3.7 **Promotion** means the appointment of an officer already serving in the Public Service, to a position at a classification higher than that of the officer's substantive position in the same Department or another Department, or a Provincial or Local Level Government Organisation.
- 3.8 **Transfer** means the appointment of an officer already serving in the Public Service, to a position at a classification equivalent to that of the officer's substantive position, in the same Department or another Department, or a Provincial or Local Level Government Organisation.
- 3.9 **Appointment** means the notification to a person that he or she has been selected either for engagement as a probationary officer, as a Senior Officer on contract, or as an employee on short term contract, or for promotion, or for transfer.
- 3.10 **Selection** is the actual process used to identify the most suitable candidates for recruitment, promotion or transfer.

Objectives

- 3.11 This General Order has been determined by the Secretary, Department of Personnel Management to ensure that the most suitable candidates are selected **solely on their own merit**, from those who have the required qualifications, abilities and job interests, and that no nepotistic, regional or political interests are allowed to influence the selection and appointment process.
- 3.12 Effective selection aims to choose the best available candidate for the position who will be capable of good performance in the short term, who will stay with the organisation, and who has potential for future development. The procedures enable recruitment to take place as quickly and efficiently as possible whilst maintaining proper standards of recruitment and selection.
- 3.13 The Government HR & Payroll Management System is to be utilised by Departments and Provincial Administrations for the purpose of maintaining establishment and staff on strength records which can be reconciled with the payroll information for purposes of monitoring and audit both internal and external to the agency. The Department of Personnel Management shall facilitate proper training and instructions for compliance with this General Order.

PROCEDURES FOR RECRUITMENT & SELECTION

- 3.14 All recruitment, promotions and transfers **must** be made through the selection process described in this General Order. The only exception to this provision relates to **transfers between agencies which are to be** effected by the Secretary, Department of Personnel Management.
- 3.15 Recruitment and selection functions have been delegated to Departmental Heads, and decentralised in order to make Departments and Provincial Administrations accountable for their selection and appointment decisions and to streamline and "speed-up" the process.
- 3.16 In order to recruit, promote or transfer an officer through the proper selection procedures,

there are a number of steps which a Department must follow. Failure to follow the correct procedures may result a selection decision being declared invalid. The diagram attached at **Schedule 3.1** summarises the procedures involved in the recruitment and selection process.

- 3.17 Appointments of Deputy Secretaries and Deputy Administrators shall be managed through a special selection panel with the engagement of competent HR persons from outside of the organisation, to advise the Departmental Head or Provincial Administrator.
- 3.18 Officers of the Department of Personnel Management are available to give assistance to Departments/Provincial Administrations in order to ensure that they follow the procedures in this General Order.

FILLING VACANT POSITIONS – STAFF & CASH CEILINGS

- 3.19 Vacant positions are identified from the Department's/Administration's organisational establishment as determined under General Order 2 utilising delegated powers. Establishment positions are given funding authority **in accordance with funded staff and Cash Ceilings approved in annual budgets.**
- 3.20 If a position is vacant **and funded** then advertisement and selection may proceed, **subject to any other restrictions that may be in place as a result of Government priorities enforced under Special General Orders**, and provided that **APPROVED FUNDED STAFF AND CASH CEILINGS (see General Order 2) ARE NOT EXCEEDED.**
- 3.21 The Departmental Head is responsible for ensuring the staff and cash ceilings issued in the annual budget (or as revised during the year) are not exceeded. Accurate and up to date records on staffing must be kept to ensure this takes place.
- 3.22 **The Secretary, Department of Personnel Management may halt all recruitment and selection in a Department or Provincial Administration, in the event that staff and cash ceilings are exceeded, or if accurate and up to date staff records are not maintained, or in the event that staff statistics are not reported in accordance with this General Order.**

STAFF ON STRENGTH RECORDS FOR PURPOSES OF RECRUITMENT

- 3.23 Accurate staff on strength records shall be maintained by Departmental Heads and recruitment and appointment progress in filling vacant positions. Records up to date at each payroll run shall be held electronically within the Government Integrated HR / Payroll Management System in such a way that the Department of Personnel Management may access the records at any time.
- 3.24 Records on staffing must consist of the following and reconciled with physical staffing records no less than at quarterly intervals:
- (a) An Establishment Register and an Unattached or Long Term Suspensions List containing the information set out in **Form RS3.18 and Form RS3.19**. These must be updated.
 - (b) A Payroll Reconciliation to be prepared on **Form RS3.17**.

- (c) A quarterly report on the progress of filling of vacant funded positions.

Staffing and Establishment Quarterly Budget Reviews

- 3.25 These records are generally for internal departmental use but can be requested at any time by the Secretary, Department of Personnel Management. These records ***must*** be available at Staffing and Establishment Reviews and audits

Maintaining staff Statistics in Government HR & Payroll Management System

- 3.26 It is the responsibility of the Departmental Head to maintain accurate staffing records in the **Government Integrated HR/Payroll Management System**, using the Positional Occupancy and other related forms in General Order 3.

ADVERTISEMENT OF VACANT POSITIONS

- 3.27 All vacant positions must be advertised **prior to any appointment being made**. Because many vacancies will be filled from within the Public Service, all positions shall be advertised internally. The Departmental Head shall ensure that suitable applicants are not available within the Public Service, the Department may not advertise in the local media without first or simultaneously advertising internally.
- 3.28 In the event that the Departmental Head or Administrator demonstrates that all past attempts to fill positions with National officers have failed, and that no qualified personnel are available within Papua New Guinea, then he may seek approval from the Secretary, Department of Personnel Management to advertise overseas under General Order 11, without advertising again within Papua New Guinea.

Acting Appointments Pending Proper Recruitment and Selection

- 3.29 The Departmental Head or Administrator shall be responsible for preparing advertisements, and for meeting the costs involved in advertising in the media and in the National Gazette, which is optional. The Departmental Head may make acting appointments from within his/her own organisation, or in special circumstances only, under General Order 10, on short term National contracts, prior to positions being advertised, also subject to the time limitations on acting appointments imposed under General Order 4.

Recruitment of School Leavers etc. to Base Level Positions

- 3.30 A Departmental Head or Administrator may wish to recruit persons who are just about to leave school, a training institution or university, in order to fill vacancies in Base Level Positions.
- 3.31 A Departmental Head or Administrator may identify potential applicants either through a recruitment campaign within schools, training institutions or the universities, or by screening school and training institute leaver forms. These forms are filled in by leavers and submitted to the Central Selection Unit at the Commission for Higher Education. Departments should contact the Commission if they wish to consider these leavers for Base Level Positions.

- 3.32 Notwithstanding General Order 3.27, formal advertisement is not a pre-requisite for recruitment to the vacant Base Level Position. In order to attract applicants, recruitment campaigns may be mounted in the schools and colleges. However, the selection process for recruitment to Base Level Positions is the same as for the filling of any other vacant position (see General Order 3.39 to General Order 3.106).

Advertising in the National Gazette (Optional)

- 3.33 At such time that a vacancy arises, the Department in which the vacancy exists may if it so decides advertise the vacancies in the National Gazette, by submitting **Form RS 3.1** to the Government Printing Office. All documents must be signed by the Departmental Head/Administrator and be accompanied by a copy of the Job Description under General Order 2.
- 3.34 A notice in the National Gazette will show the Position Number, Designation/Local Designation, qualifications, salary grade and range, whether or not a position is on contract, name of officer and contact number for further information about the vacancy (for example, a copy of the Job Description) and the forwarding address for applications.

Advertisement of Vacancies in the Local Media

- 3.35 It is the responsibility of the Department where the vacancy exists to prepare the advertisement for placing in the media, and meet all costs involved with the advertisement.
- 3.36 An advertisement should contain the following particulars of the vacant position:
- (a) the job title and establishment position number of the position, and whether contract or non-contract;
 - (b) the salary grade and PBSS rate and relevant allowances applicable under General Order 13 and General Order 9;
 - (c) a brief description of the duties;
 - (d) job requirements including qualifications taken from the job description;
 - (e) experience or special skills required;
 - (f) the date by which the applications are to be made;
 - (g) the forwarding address for applications; and
 - (h) the name and phone number of the contact officer to whom enquiries may be directed and who can provide job descriptions.
- 3.37 With regard to advertisements in the local and overseas media, the duties shown for each of the positions advertised may only be a brief summary of the tasks to be performed. Further information about the position can subsequently be provided by the contact officer named in the advertisement.

N.B. All organisations must have their approved job descriptions Form OD2.7 stamped by the Departmental Head before advertisement.

Advertisement of Vacancies Overseas

- 3.38 Provided that the Departmental Head/Administrator has complied with the requirements of this General Order, and General Order 11, the vacancy may be advertised overseas. Under no circumstances shall a non-citizen be recruited from overseas if there are Papua New Guinean citizens who wish to apply for the vacancy.

APPLICATIONS FOR VACANT POSITIONS

- 3.39 Applications for vacant positions shall be made on **Form RS 3.2**, which must be freely available within Departments/Administrations for all aspiring candidates.
- 3.40 Applications for positions appearing in the National Gazette will normally only be considered from Papua New Guineans. All applications must be fully completed in all respects. For example, documentary evidence of any required qualifications must be provided with the application.
- 3.41 All applications (only one copy is necessary) must bear the personal signature of the applicant. A signature of proxy is not acceptable.
- 3.42 All applications must be submitted and received by the employing agency before the closing date and time. Applications by facsimile without full documentation may be accepted prior to the closing date and time, provided that the facsimile is followed immediately by a written application with full supporting documentation. Late applications must not be considered under any circumstances.

THE SELECTION PROCESS

- 3.43 The Selection process commences with receipt of completed application forms, and ends with the appointment of a successful applicant. Personal references must be obtained from previous employers and nominated referees for consideration by the Selection Committees.

Selection of Deputy Secretaries and Deputy Administrators

- 3.44. Selection to the positions of Deputy Secretary and Deputy Administrator shall be subject to a recommendation to be made to the Departmental Head or Administrator, by the Selection Committee chaired by a delegate of the Secretary, Department of Personnel Management, who shall be another Departmental Head or Provincial Administrator or senior officer from outside of the Department or Administration.
- 3.45 Voting Members of the Selection Committee for selection of Deputy Secretaries/Deputy Administrators, which also constitutes the quorum as all must be compulsorily present, shall be as follows:
- (a) the Chairman, shall be a delegate of the Secretary, Department of Personnel Management, a senior officer from outside of the said organisation, competent in the administration of the selection and appointment process; and,

- (b) another Departmental Head or Provincial Administrator or their delegate; and
- (c) an officer appointed from the Department of Personnel Management by the Secretary, Department of Personnel Management, and
- (d) the Head of the Department's Human Resource Management Unit (non-voting).

3.46 The Chairman of the Selection Committee shall make a recommended short list of the candidates in order of merit to the Departmental Head or Provincial Administrator who shall make an appointment, where considered necessary, in consultation with the Secretary, Department of Personnel Management.

COMPOSITION OF THE NATIONAL DEPARTMENT/PROVINCIAL ADMINISTRATION SELECTION COMMITTEE

3.47 Each Departmental Head or Provincial Administrator shall be responsible for administering its own Selection Committee and making selection decisions, **subject to the conditions of this General Order**. A **Selection Committee** shall consist of the following members:

- (a) the Chairman, who shall be the Departmental Head/Provincial Administrator or his/her delegate, who shall be an officer at Deputy Secretary or First Assistant Secretary level, or, as determined by the Departmental Head in his/her sole discretion, a delegate of the Secretary, Department of Personnel Management; and,
- (b) the Deputy Chairman, who shall be an officer at Deputy Secretary or First Assistant Secretary level, who may be from outside the Department in which the vacancy exists, and who shall be a delegate of the Secretary, Department of Personnel Management (per the provisions of this General Order); and
- (b) the Divisional Head of the Division in which the vacancy exists; and,
- (d) the Head of the Human Resource Management Unit of the organisation; and
- (e) a delegate of a Departmental Head of a National Department, where a position of Principal Adviser of a National function is being recruited in a Province.

3.48 The departmental delegate(s) (from within the organisation) of the Secretary, Department of Personnel Management **shall compulsorily be present** at each selection hearing, and shall be the principal adviser(s) to the Chairman, on interpretation of General Orders, and the Chairman shall not unreasonably ignore the advice given.

3.49 Provided that in the event that members of the Committee are not in attendance, and that the views of the absentee members have been obtained by the Chairman, particularly with regard to the views of a Head responsible for a National function in the Province, then the Committee may proceed to make a selection decision, on the basis of a quorum of members present, which shall be the Chairman plus the Deputy Chairman plus the Head of the employing division, plus the delegate of the Secretary, Department of Personnel Management in the agency.

- 3.50 On the advice of the Departmental delegate, the Secretary, Department of Personnel Management may annul any decision of a Selection Committee which has been made contrary to these General Orders. A person displaced from office in this manner shall automatically become an unattached officer at his/her former substantive level, unless the Departmental Head is able to retain the officer in his or her former substantive position.
- 3.51 Where the provisions of General Order 3 and any Special General Orders that may be in force are persistently not complied with, the Secretary, Department of Personnel Management retains may withdraw the authority of the Selection Committee, and assume responsibility for all selection and appointment matters in the organisation.
- 3.52 The members of any Selection Committee established under this General Order are not, while acting as such, subject to direction or control by any person or authority, and before taking up the duties of their office the members of the Selection Committee shall take an oath of the office on **Form RS 3.3**.

RECEIVING AND ACKNOWLEDGING APPLICATIONS

- 3.53 All completed applications shall be referred to the Chairman of the Selection Committee, and the Chairman will be responsible for acknowledging receipt of each application on **Form RS 3.4**, and may, if appropriate, reject any applications which are unsigned, unduly late or do not conform with the application requirements in any other way. This will be notified to the unsuccessful applicant on **Form RS 3.5**.
- 3.54 The Chairman of the Selection Committee shall be responsible for preparing a complete list of all applicants for each advertisement received on **Form RS 3.6** and the Chairman may delegate some or all of these responsibilities to other members of the Selection Committee, or to officers of the Department, provided that the Chairman remains accountable for the validity of the work undertaken.

SHORT LISTING OF APPLICANTS

Establishing Selection Criteria

- 3.55 The Selection Committee shall determine from an up to date job description **Form OD2.7** selection criteria against which to judge each applicant. Examples of selection criteria include:
- (a) minimum educational requirement/vocational/professional qualifications;
 - (b) previous work experience;
 - (c) competencies, relevant skills, such as personal qualities, abilities, and special knowledge;

Preparing a Shortlist

- 3.56 Having established the criteria to be used, the Selection Committee shall prepare a shortlist of applicants from the list of applicants who have been considered against the defined standards of education and other statutory requirements. Applicants shall not be

excluded solely because of the Committee's unfamiliarity with overseas qualifications or the institutions from which the qualifications were obtained, and where necessary expert advice shall be obtained from the Commission of Higher Education, the Universities or other competent bodies.

- 3.57 In considering an applicant's background and work experience, a Selection Committees shall focus on assessing the skills and competencies obtained rather than on the context of their work experience. For example, an applicant who has had extensive and successful experience in a supervisory area other than solely the area of an advertised position should have these supervisory skills considered on their merits.
- 3.58 Referee reports should be sought to assist short-listing. Any applicant who has not met the minimum eligibility requirements or who has been assessed as unsuitable in terms of the selection criteria should be advised at this stage, in writing, his application has been unsuccessful on **Form RS 3.5**.
- 3.59 The Selection Committee may, in its discretion, consider each applicant for the Shortlist on the basis of a summary of each applicant prepared by a member of the Selection Committee. This summary should include the applicant's qualifications, current job, previous work experience and any other relevant information. This procedure will avoid the need to copy and circulate all applications to all members of the Selection Committee. ***However, the full original documentation of each applicant must be made available at the selection hearing, to enable any member of the Selection Committee to cross check the summary information for himself/herself.***

REFERENCE CHECKING

- 3.60 In addition to interviewing short-listed applicants, the Selection Committee shall check the references supplied by short-listed applicants.
- 3.61 References are an important element in the selection process and need to be obtained and checked in a structured and objective manner. Committee members shall require all candidates to supply the names and addresses of three referees.
- 3.62 The most valuable referee is usually the candidate's current or recent supervisor who has observed the candidate's performance over a reasonable length of time. Referees should be able to provide information on competencies, experiences and other characteristics that cannot be fully assessed at the interview.
- 3.63 Reference reports may be obtained orally or in written form, before or after the interview to gain added information that may confirm or counterbalance what is already before the committee. If referee checks are conducted over the phone then a standard **Form RS 3.8 and Form RS3.9** should be used to record the data obtained, for uniformity.
- 3.64 It is a serious offence for a person to be included in the selection process and for an offer of employment to be made without a recorded reference being obtained, showing that the candidate has no previous work history to disbar him or her from Public Service employment.

PROCEDURES FOR CONDUCTING SELECTION HEARINGS

Pre-interview Arrangements

- 3.65 Applicants shall be given sufficient notice of the interview time to enable them to prepare for the interview. A week would be desirable and anything less than two days would be insufficient. In addition, applicants must be advised to bring along required documentation to the interview including references and originals of certificates etc.
- 3.66 Background material and information on the job and the work area may also be made available by the Department before the interview, particularly where applicants are not from the Department concerned.
- 3.67 Where short-listed applicants are from another locality, arrangements may have to be made to interview them there, or to transport them to the interview location.

Scheduling Interviews

- 3.68 Interviews should be scheduled as soon as possible after the short listing of applicants.

Timing

- 3.69 The timing of interviews is of considerable importance. A long wait beforehand or a rushed interview can be very disturbing to the interviewee and short interviews can affect a Committee's ability to make a sound, accurate selection decision. Sufficient time should be allowed during the interview for thorough questioning of the applicant and for any questions the applicant has to ask.

Conducting the Interview

- 3.70 Prior consideration should be given to the types and range of questions to be asked of individual candidates at interview, to ensure their purpose, consistency and clarity.
- 3.71 It is highly desirable that questions be structured to gain information about the relevant past behaviour of the applicant and particularly performance against the accountabilities and duties of the vacant position. This enables the Committee to assess the candidate's competencies against the minimum acceptable criteria.
- 3.72 The Committee should ensure that there is a good physical setting for the interview. Furniture should be arranged so that the interviewee is comfortable and can easily see the Committee members and keep eye contact. There should be no interruptions in the form of phone calls or visitors.
- 3.73 The interviewee should be escorted into the interviewing room and introduced to the members of the Committee.
- 3.74 The Committee should ensure that the interviewee is familiar with the duty statement and selection criteria.
- 3.75 The information provided by the interviewee can only be judged fairly if the Committee establishes effective communication with him and maintains a constructive and

non-aggressive approach to the interview as a whole. An effective way of establishing this communication is to begin by giving an outline of the position and its main duties and then ask factual questions structured for the purpose of identifying important competencies/abilities and experiences of the applicant.

- 3.76 The Committee must ensure that no employment commitment is entered into or implied and that decisions are not given on any matter involving conditions of service until cleared by the appropriate approving authority.
- 3.77 Before the closing of the interview, the Chairman should give the interviewee an opportunity to seek or provide extra information that may not have been covered in the interview.
- 3.78 The interviewee shall be informed when he/she will be notified of the final selection decision within a period of 6 weeks from the interview date and no later.
- 3.79 After each interview, short notes should be made about the candidate, including aspects needing clarification through further discussions with the referees. Each member of the committee should prepare these separately. Such summary notes provide a basis for making a later assessment of the relative merits of candidates by the whole Committee and assist in the preparation of the Committee's report. The use of standard format for such notes will facilitate this process. This is detailed on **Form RS 3.8 and Form RS3.9**.
- 3.80 **Form RS 3.8 and Form RS3.9** is to be used by members of the Pre-Selection Committee when interviewing applicants. After reference checks have been made, the consensus decision of the Committee is recorded on the form.
- 3.81 Interview costs shall be met by the Department in which the vacancy exists.

THE PRE SELECTION DECISION AND REPORT

- 3.82 Having considered all applications, conducted interviews where necessary, and checked references as applicable, the Selection Committee will rank the short-listed applicants in order of preference using **Form RS 3.7A**. The HR Manager/Delegate is secretary to the Committee.
- 3.83 The Committee must make a complete report of its deliberations and decisions. The report must contain all the essential information which the committee used to arrive at its decision to select a candidate for an advertised vacancy. Comments in the report must be substantiated. Any irregularities or inconsistencies not resolved by the Committee should be mentioned in the report.
- 3.84 The Final Selection Report (**Form RS3.16**) shall include the following:
- (a) details of the position to be filled, name of the department, division, branch, position number, Gazette number or date of advertisement (or reason for not advertising), designation, local designation, classification, location, main duties and qualifications;
 - (b) the number of applicants;

- (c) the criteria used for shortlisting and the number shortlisted;
 - (d) the name of each shortlisted applicant with a reason for their rejection;
 - (e) the reasons for selecting the successful applicant; and,
 - (f) appendices which should include completed **Form RS3.1 to Form RS3.10**, and the names and designations of the Selection Committee.
- 3.85 The Selection Committee report prepared along the above lines, in addition to being the prime working document for the Selection function, will be useful as a reference document for use in case of an appeal. Relevant parts of the report would normally form the basis of the Department's case. The report itself may be made available to the Public Services Commission to give a full account of the grounds of original selection decision should an applicant appeal against a selection decision.

NOTIFICATION OF THE SELECTION COMMITTEE'S DECISION

- 3.86 The Selection process concludes with formal action to recruit, promote or transfer an officer to the advertised vacancy or not to fill the vacancy.
- 3.87 The Department concerned shall advise the successful and unsuccessful applicants of the outcome of their applications and complete the necessary administrative arrangements as indicated below. Applicants should in any case be advised of the current status of their applications if a vacancy has not been filled within three months of it being advertised.

Notification of Successful Applicants for Promotion or Transfer

- 3.88 If the Selection Committee decides to promote or transfer an officer to the vacant position, the Chairman of the Committee will notify the successful permanent officer on **Form RS 3.11**.
- 3.89 The Chairman of the Selection Committee will also notify the Department where the vacancy exists, and any other Department affected, on **Form RS 3.12**. (A copy shall also be sent to the Secretary, Department of Personnel Management for formal notification in the National Gazette.)
- 3.90 The Selection Committee's decision is final except where an officer declines promotion or transfer within the specified time. If the officer does decline the promotion or transfer, then the Selection Committee may decide to appoint another applicant from the shortlist rather than re-advertising the position. If it is not possible to appoint another officer from the short list, then the position shall be re-advertised.

Notification of Successful Applicant for Appointment as a Probationary Officer

- 3.91 The Chairman of the Selection Committee will notify the candidate of a **conditional offer** on **Form RS 3.13**. This conditional offer will be confirmed after the applicant has fulfilled the requirements for appointment to the Public Service as a probationary officer, outlined in this General Order.
- 3.92 Where the successful applicant is from outside the Public Service, for appointment as a Probationary Officer the applicant must provide to the Chairman of the Selection

Committee:

- (a) a medical certificate indicating good health;
- (b) evidence of date of birth, from a birth certificate, a church leader, or census records;
- (c) certified copies of any required qualifications;
- (d) a character reference (eg from a bank manager, doctor, lawyer, commissioner for oaths, previous employer, etc.);
- (e) a work reference from the current or immediate past employer; and
- (f) a police clearance.

Documentation under (c) and (e) should have accompanied the candidate's original application, so that documentation under (a), (b), (d) and (f) must be provided by the successful candidate within 30 days from receipt of the offer.

- 3.93 The successful candidate shall provide in writing to the Chairman of the Selection Committee, confirmation of his acceptance of the conditional offer together with the balance of documentation required under GO 3.92 within 30 days effective from the date of selection or the offer will be withdrawn. In the event that the successful candidate is unable to comply with this requirement, he or she will be advised that the offer has been withdrawn in completed **Form RS 3.5**.
- 3.94 If the successful candidate provides the required information within the prescribed time limit, the Chairman of the Selection Committee will write to the Departmental Head, requesting approval to recruit. This should be done on **Form RS 3.12**.
- 3.95 The Departmental Head will notify the Chairman of the Selection Committee of his decision by signing and returning on **Form RS 3.12**. If the Selection Committee Chairman is also the Departmental Head, then this approval can be given immediately by the Departmental Head completing the whole form.
- 3.96 If approval to recruit has been given, the Chairman of the Selection Committee shall notify the successful applicant on **Form RS 3.13**. In this case, the person should report to work as soon as possible.
- 3.97 As soon as the probationary appointment is made, the person shall complete an Oath or Affirmation indicated on Forms 4.1 or 4.2 in General Order No.4.
- 3.98 Prior to a new probationary officer being placed on payroll, the Department of Personnel Management will be required to issue an Employment File Number.
- 3.99 A person offered employment in the Public Service shall respond within 30 days of receipt of the offer. Failure to respond within this time period may be taken as a refusal of the offer. In the event that the person rejects the offer of appointment, then the Selection Committee may decide to appoint another applicant from the shortlist. If the Selection Committee cannot appoint another applicant from the shortlist, then the position shall be

re-advertised.

Notification of Unsuccessful Applicants

- 3.100 The Chairman of the Selection Committee shall notify any rejected shortlisted candidates on **Form RS 3.5**. If the Selection Committee has more than one applicant who it considers suitable to fill a vacancy, the Committee may prefer to delay rejecting applicants until their most preferred candidate has been appointed, promoted or transferred. All applicants must be notified no later than six weeks following conclusion of the selection hearings.
- 3.101 In the case where the most suitable candidate does not accept the offer, the Committee may make an offer to the next preferred applicant and so on.

THE NATIONAL GAZETTE - PRINTING AND DISTRIBUTION

- 3.102 The Government Printing Office is responsible for the printing and distribution, on a monthly basis or as required of the National Government Gazette which contains information concerning advertised vacancies.
- 3.103 For a Department or Administration to receive regular copies of the National Government Gazette, it must inform the Government Printing Office in writing by the first week of January each year indicating the number of copies it will require and its postal address.

ENGAGEMENT OF EXTERNAL RECRUITMENT AGENCIES

- 3.104 The Head of a Department may, in consultation with the Secretary, Department of Personnel Management, engage a reputable external recruitment agency where it is considered that external intervention is necessary due to lack of HR Management capacity or need for an impartial pre-selection process. But this engagement must be restricted to the purpose of advertising and/or determining a shortlist of applicants. The role of the Selection Committee must not be contracted out to an external recruitment agency.

ROLE OF THE HR MANAGER IN THE SELECTION PROCESS

- 3.105 The Manager of the relevant HR or Corporate Services Branch will be responsible for the administration of applications and correspondence to the applicants. Decisions to accept or reject an application on the grounds of compliance or submission timeliness will be made by the HR Manager, subject to confirmation by the Chairman of the Selection Committee, and for this purpose, the HR Manager will provide a complete list of all applicants received for scrutiny by the Selection Committee.

GUIDELINES FOR MAINTENANCE OF STAFF RECORDS

- 3.106 If a position is vacant and funded then selection may proceed. The Departmental Head is responsible for ensuring that staff ceilings are not exceeded. Accurate and up to date staff records must be kept to ensure this. Failure to keep within ceilings or failure to keep adequate staff records may result in a ban on recruitment and selection in the concerned department. The following paragraphs give guidance as to how staff records should be maintained and reported.

Monthly

- 3.107 Complete Form RS3.16, Form RS3.17, Form RS3.18, OD Table 1, OD Table 2 and OD Table 3
- 3.108 Complete **Form SE 5**. Enter "Previous Months Total" which must be equal to the "Total this Return" figure in last month's SE 5. Enter "Cessations" and "Commencements" (this must include transfers in and transfers out) from **Forms SE 1 and SE 2**.

Subtract "Cessations" and **add** "Commencements" to the "Previous Months Total" and the result should be entered in the "Total this Return" column.

- 3.109 The completed information must be input to the Government HR & Payroll Management System in the specified HR module for monitoring by the Central Agencies.

Quarterly

- 3.110 Update the Establishment Register held in the Government's HR & Payroll Management System, utilising the data gathered and recorded in Forms SE1 to SE5.
- 3.111 Update the Unattached Officers/Long Term Suspensions List, held in the Government's HR & Payroll Management System.
- (a) Record all unattached officers on this form ensuring that officers that have been made unattached in the last quarter are recorded.
 - (b) Previously unattached officers who have won positions in the last quarter should be removed from this form.
 - (c) Adjust Long Term Suspensions to reflect the position at the end of the quarter.

Payroll Reconciliation

- 3.112 Make a Payroll Reconciliation in the Government HR & Payroll Management System each quarter using information from the payroll and information from the Establishment Register and Unattached Officers/Long Term Suspensions List all held in the system.
- 3.113 Staff on Strength is defined as *all* staff on the payroll who are not terminated, including all those paid each fortnight plus all those suspended for *any reason*.
- 3.114 Staff on Strength as defined above should be entered on the Payroll Reconciliation Form by cost code and sub-totalled by activity.
- 3.115 Enter a staffing figure for each cost centre activity held in the Establishment Register and Unattached/Long Term Suspensions List, consisting of:
- every position which has an actual occupant; plus,
 - every unattached and long term suspended officer who is *not* currently the actual occupant of a position.

- 3.116 The two staffing figures thus entered into the Payroll Reconciliation file should be equal. If they are not then the reason should be properly identified and rectification made:
- (a) Wrong cost coding on the payroll, or,
 - (b) Officers who have left the Public Service and who should therefore be recorded as terminated but are currently recorded as suspended, or,
 - (c) Officers are being wrongly paid out of an incorrect Item instead of Item 1 or vice versa.
- 3.117 It is the payroll Staff on Strength figure which will be used by the Treasury Audit Committee to assess a department's staffing level as against the staff ceilings. It is therefore in each Departmental Head's interest to ensure that officers, on leaving the Public Service are immediately terminated from the payroll. Suspensions from the payroll should only be used for officers who are temporarily absent from duty.

Instructions for Completing Establishment Register - Position Occupancy (Form 2.14)

- 3.118 Maintain a set of data in the government HR & Payroll Management System in respect to each organisational section in the Department/Provincial Administration.
- 3.119 Enter Department, Division, Branch, Section and Budget Activity number and the date.
- 3.120 Complete one line for every funded position in the Section. For each position, the DPM Position Number, Designation, Classification and Location **MUST** be entered.
- 3.121 Occupancy information to be entered as follows:
- (a) Substantive Occupant. Enter name and number where an officer has won the position.
 - (b) Actual Occupant. Enter name and number where an officer is actually performing the duties of the position and is being paid against the position.

IMPORTANT

1. In the event that an officer is actually performing the duties of a substantively held position (not acting in another position), the officer's name will be entered in the substantive and actual columns.
2. In the event that an officer has not won the position but is acting in it, then enter that officer in the Actual Occupant column, even if the officer is unattached. Enter any other matters here relating to the position. For example:
 - (i) If a separate project within a Section has a different Budget Activity code, enter the position's Budget Activity code here.
 - (ii) Indicate recruitment action taken or planned.

Instructions for Completing Unattached Officers and Short/Long Term Suspensions
- Form RS3.18 and Form RS3.19

- 3.122 Ensure that the HR & Payroll Management System is configured in the same manner as the Establishment Register.
- 3.123 For every Unattached Officer and Long Term Suspended Officer, enter number, name, and if applicable, Designation and Classification of substantive position level.
- 3.124 Enter substantive position number in the case of a suspended (ie suspended from payroll) officer who holds a substantive position.
- 3.125 If the officer is unattached, enter reason, (for example, overpaid, position abolished, position upgraded, etc).
- 3.126 If the officer is on Long Term Suspension, enter reason (for example, furlough) and date of suspension.
- 3.127 If the officer is actually occupying a position, enter position number.



PUBLIC SERVICE OF PAPUA NEW GUINEA

SELECTION PROCESS CHART

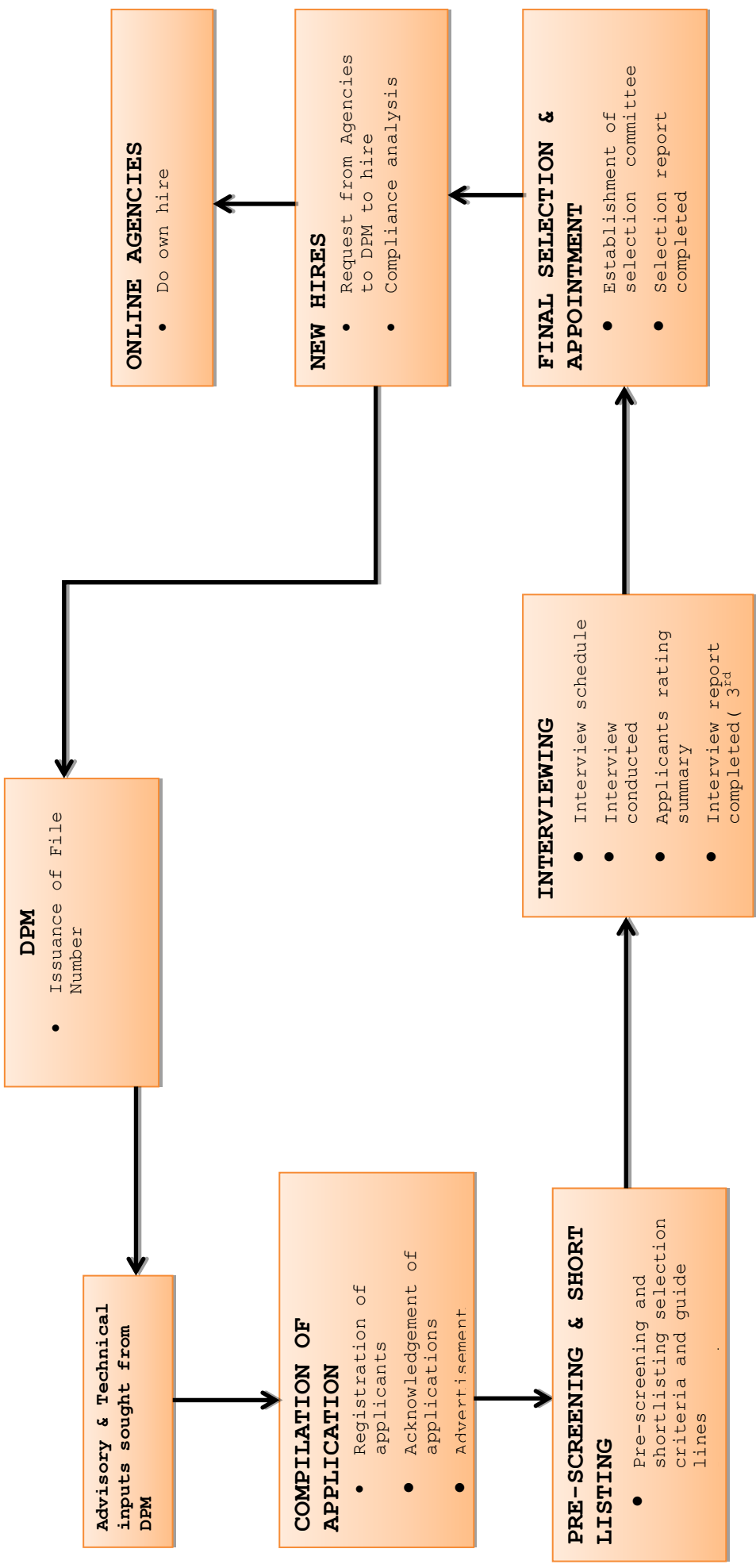



PUBLIC SERVICE OF PAPIUA NEW GUINEA

AGENCY.....
DETAILS OF POSITIONS FOR ADVERTISEMENT IN THE NATIONAL GAZZETTE

APPROVED POSITION No.	DESIGNATION	CLASSIFICATION	REQUIRED QUALIFICATION	SALARY RANGE	LOCATION	NAME & CONTACT No. FOR FURTHER INFORMATION	FORWARDING ADDRESS

I certify that the positions listed are vacant and funded and that filling the positions will not cause my department to exceed its approved staffing, establishment and cash ceiling.

.....
Signature of Departmental Head
 (or his/her delegate)

.....
Date

PUBLIC SERVICE OF PAPUA NEW GUINEA
APPLICATION FOR EMPLOYMENT

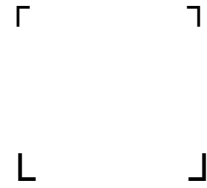

PLEASE COMPLETE IN FULL IN BLOCK LETTERS USING BLACK OR BLUE INK OR IN
 TYPESCRIPT

RECENT PHOTOGRAPH

POSITIONS APPLIED FOR					POSITION NUMBER
NAME:					<input type="checkbox"/> MALE
Surname					<input type="checkbox"/> FEMALE
Given Names					
NAME AT BIRTH (if different)			ANY OTHER NAMES USED		
DATE OF BIRTH	PLACE OF BIRTH	DISTRICT/CITY	PROVINCE/STATE	COUNTRY	
/ /					
CITIZENSHIP			If naturalised Citizen, Nationality at birth:		
MARITAL STATUS	<input type="checkbox"/> MARRIED		<input type="checkbox"/> SEPARATED		<input type="checkbox"/> WIDOWED
	<input type="checkbox"/> SINGLE		<input type="checkbox"/> DIVORCED		
If married	Date of Marriage/...../.....	Spouse's Employer		Spouse's File Number (if Govt. employed)	
HAVE YOU ANY CHILDREN? If yes, give details below					
NAME		MALE/FEMALE		DATE OF BIRTH	
1.....					
2.....					
3.....					
4.....					
5.....					
6.....					
7.....					
PERMANENT ADDRESS				TELEPHONE No :	
PRESENT ADDRESS (if Different)		until/...../.....	TELEPHONE No :	
	FULL POSTAL ADDRESS				DATES

PLACE OF RESIDENCE LAST FIVE YEARS (Other than vacation)/...../...../...../.....
	to
/...../.....
	to
/...../.....

SECONDARY EDUCATION

SCHOOL:		SCHOOL:	
Name of Examination	Year Passed	Name of Examination	Year Passed
SUBJECT	Result	SUBJECT	Result
.....
.....
.....
.....
.....
.....
.....
.....
.....

TERTIARY EDUCATION

UNIVERSITY, COLLEGE	
COURSE	
DURATION	TO
QUALIFICATION OBTAINED	

Give details of ALL branches of subject taken:

SUBJECT		SUBJECT	
YEAR 1		YEAR 3	
YEAR 2		YEAR 4	

ADDITIONAL QUALIFICATIONS, FURTHER STUDY, RESEARCH

PUBLICATIONS	
PRIZES, SCHOLARSHIPS, etc	
MEMBERSHIP OF LEARNED SOCITIES OR INSTITUTES (Give date of admission and level of membership)	

EMPLOYMENT RECORD

PRESENT POSITION OR LATEST POSITION HELD		DESCRIPTION OF WORK, INCLUDING SUPERVISORY DUTIES
Name and Address of Employer	
Title of Job	
Period	/ / to / /
Present Salary..... If on Salary Range, please state range:.....	
PREVIOUS POSITION HELD - in reversed consecutive order		
Name and Address of Employer	
Title of Job	
Period	/ / to / /
Name and Address of Employer	

Title of Job				
Period	/ / to / /			
Name and Address of employer				
Title Of Job				
Period	/ / to / /			
Name and Address of Employer				
Title of Job				
Period	/ / to / /			
Name and Address of Employer				
Title of Job				
Period	/ / to / /			
CIVIC ACTIVITIES, CLUBS/ SOCIETIES				
INTERESTS, SPORTS/ RECREATION				
CLOSE RELATIVES	FULL NAME (including maiden name)		DATE OF BIRTH	ADDRESS
	FATHER			
	MOTHER			
	SPOUSE			
SERVICE IN THE ARMED FORCES	BRANCH OF SERVICE :			
	RANK :		DATE OF ENLISTMENT: .../.../.....	
	DATE DISCHARGED: / /		REASON:	
<p>Have you been convicted of an offence? If YES, give details.</p> <input type="checkbox"/> NO <input type="checkbox"/> YES				
PREVIOUS APPLICATIONS FOR POSITIONS IN PAPUA NEW GUINEA	Position	Authority		Date

REFERENCES: Name four persons who can comment on your academic work or on your professional experience. Before nominating them you should have their permission to give their names. We will wish to approach referees before interview. If , however, an approach to any particular referee is inconvenient at present, please indicate:*

Name and Position	Relevance	Address	Tel. No.
1.			
2.			
3.			
4.			

If applying for an advertised vacancy, journal in which advertisement seen:

NOTE: THE DISCOVERY OF ANY INCORRECT OR MISLEADING STATEMENT OR DELIBERATE OMISSION COULD RENDER ANY EMPLOYMENT OR CONTRACTUAL AGREEMENT VOID WITHOUT COMPENSATION OR REPATRIATION

SIGNATURE:		
OFFICE USE ONLY	Notice.....weeks	BC Sighted.....
	M/C Sighted.....	N/C Sighted.....
	Acc. Sit Exp.....	



PUBLIC SERVICE OF PAPUA NEW GUINEA

OATH OF OFFICE

MEMBERS OF THE PUBLIC SERVICE SELECTION COMMITTEE PUBLIC SERVICES (MANAGEMENT) ACT 1995

I, do swear that I will well and truly serve the Independent State of Papua New Guinea in the Office of a Public Service Selection Committee under the Public Services (Management) Act 1995.

So help me God!

And furthermore I do solemnly and sincerely declare that I will at all times maintain secrecy in respect of any personal information disclosed to me in my capacity as Chairman (or Member) of a Public Service Selection Committee under the Public Services (Management) Act 1995 and that I will not directly or indirectly communicate or divulge any information so disclosed to me except as authorised or required by Law.

.....
(Signature)

Dated at

This..... day of 20.....

Before me:

.....
(Signature of Person authorised to take Oath)



PUBLIC SERVICE OF PAPUA NEW GUINEA

Γ

7

REF:

L

J

DATE:

ACKNOWLEDGEMENT TO APPLICANT

POSITION NO.	DESIGNATION/CLASSIFICATION	ADVERTISEMENT NO.
AGENCY	GAZETTE NO.	GAZETTE DATE/...../.....

YOU ARE ADVISED THAT YOUR APPLICATION FOR THE ABOVE POSITION HAS BEEN RECEIVED.

THE RESULTS OF YOUR APPLICATION WILL BE MADE KNOWN TO YOU ON LATER DATE.

THANK YOU FOR YOUR APPLICATION.

CHAIRMAN

SELECTION COMMITTEE

DEPARTMENT OF

Γ
L7
J**FROM:**
REF:
DATE:

NOTIFICATION TO APPLICANT

POSITION NO.	DESIGNATION/CLASSIFICATION	ADVERTISEMENT NO.
AGENCY	GAZZETTE NO:	GAZZETTE DATE:

YOUR APPLICATION WITH REFERENCE TO THE ABOVE REFERS.

PLEASE BE ADVISED THAT YOUR APPLICATION FOR THE POSITION HAS BEEN UNSUCCESSFUL FOR THE FOLLOWING REASON(S):-

- a) YOUR APPLICATION IS INCOMPLETE (E.G. NOT SIGNED ETC).
- b) THE POSITION HAS NOW BEEN FILLED BY THE MOST SUITABLE APPLICANT.
- c) YOUR CONDITIONAL OFFER OF EMPLOYMENT HAS BEEN WITHDRAWN BECAUSE YOU HAVE NOT FULFILLED THE REQUIREMENTS OF THAT OFFER.
- d) THE POSITION HAS BEEN WITHDRAWN.
- e) YOUR APPLICATION HAS BEEN LATE.

(DELETE WHICHEVER IS NOT APPLICABLE)

CHAIRPERSON
SELECTION COMMITTEE

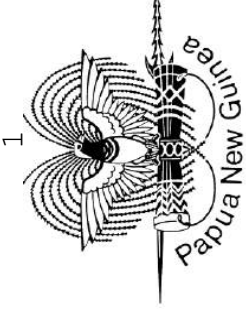

PUBLIC SERVICE OF PAPUA NEW GUINEA

REGISTER OF APPLICANTS

AGENCY	POSITION NO.				DESIGNATION/CLASSIFICATION				ADVERTISMENT NO. Mode of Advertisement
	APPLICANT NUMBER	DATE RECEIVED	ACKNOWLEDT ISSUED	NAME OF APPLICANT	Current Address	Employment Status (probationary, permanent)	PERMANENCY DATE	SUBSTANTIVE DESIGNATION	
									REMARK



**PUBLIC SERVICE OF PAPUA NEW GUINEA
SHORT LIST APPLICANT PROFILE**

Advertisement No: _____ **Position No:** _____
Advertisement Date: _____ **Designation:** _____
Mode of Advert: _____ **Classification:** _____
Total No. Of Applicants: _____

<i>POSITION SPECIFICATION</i>	<i>PERSON SPECIFICATION Applicant 1</i>	<i>PERSON SPECIFICATION Applicant 2</i>	<i>PERSON SPECIFICATION Applicant 3</i>
	Name: Age: Current Position: Address/Location:	Name: Age: Current Position: Address/Location	Name: Age: Current Position: Address/Location

Qualifications (abstract from JD)				

Other training/courses attended				
Knowledge				
Skills/Competencies				
Related Job Experience				
Performance Level (abstract from SPA)				

Ranking out of 10				
Qualification				
Experience				
Training				
Skills/Competencies				
Knowledge				
Weighting Out of 25				
Ranked				

SHORT LIST IN ORDER OF PREFERENCE

- 1.....
- 2.....
- 3.....
- 4.....
- 5.....

ELIMINATED

- 1.....
- 2.....
- 3.....
- 4.....
- 5.....

**Department or Agency Letterhead**

PRE-SELECTION AND SHORT-LISTING REPORT**1. INTRODUCTION****Date:****Time:****Venue:****2. Composition of Pre-Selection Committee:****Chairperson:****Member:****Member:****Member:****Technical Adviser:****3. Selection Criteria**

1. Educational Qualification
2. Relevant/Direct Work experience
3. Relevant./direct Training
4. Relevant skills and knowledge
5. Performance level (Based on SPA) HRM to provide SPA for internal applicants.

4. CULLING AND PRE-SELECTION SHORTLING**4.1 Deliberation****4.2 Recommendation****4.3 Short list.****Summary**

Posn.No/Grade	Total Applications	Shortlisted	Elimination	Withdrawn	Remarks

.....
CHAIRPERSON

.....
MEMBER.

.....
MEMBER

.....
MEMBER

.....
MEMBER

DATE:



PUBLIC SERVICE OF PAPUA NEW GUINEA
APPLICANT RATING SUMMARY

APPLICANT: -----
 POSITION: -----
 DATE: -----
 INTERVIEWERS: -----

SELECTION CRITERIA	INTERVIEWERS RATING & COMMENTS				CONSENSUS
	CHAIRMAN	DIV HEAD	DPM REP	SDO	
QUALIFICATION & TRAINING					
RELEVANT WORK EXPERIENCE					
COMPETENCIES/SKILLS REQUIRED					
1.					
2.					
3.					
4.					
5.					
6.					

COMMENTS:-----

SIGNED:					
ALL INTERVIEWERS:					



PUBLIC SERVICE OF PAPUA NEW GUINEA

RANK PREFERENCE OF CANDIDATES

POSITION: **DATE:**

INTERVIEWERS:.....

NAME OF APPLICANT					
ACADEMIC QUALIFICATION					
TRAINING QUALIFICATION					
RELEVANT WORK EXPERIENCE					
COMPETENCIES/SKILLS REQUIRED					
RANK IN ORDER OF PREFERENCE					

INTERVIEW COMMITTEES COMMENT(S):

.....

SIGNED:

.....
CHAIRMAN

.....
DIVISIONAL HEAD

.....
STAFF DEVELOPMENT OFFICER

.....
DPM REPRESENTATIVE

AGENCY:.....



DEPARTMENT OF PERSONNEL MANAGEMENT

SELECTION DECISION

PART A: DETAILS OF ADVERTISED VACANCY

REFERENCE	DEPARTMENT	POSITION NO:	DESIGNATION:
CLASSIFICATION:	GAZETTE:	ADVERTISEMENT NO:	DATE:

PART B: SELECTION COMMITTEE DECISION

By virtue of the Public Service (Management) Act 1995(Amended) and all other powers vested in it the Selection Committee duly considered applicants for the advertised vacancy as specified above.

The Selection Committee Decision on applicants for the advertised post as listed in the appropriate column has been made with effect from the date affixed below.

[]	[]	[]	[]	[]	[]
RE-APPOINTMENT	PROMOTION	TRANSFER	PROBATION APPOINTMENT	REJECTED	WITHDRAWN

REASONS/JUSTIFICATION:

CHAIRMAN MEMBER MEMBER MEMBER MEMBER

...../...../.....
EFFECTIVE DATE



PUBLIC SERVICE OF PAPUA NEW GUINEA

--

NOTIFICATION TO APPLICANT

DESIGNATION/CLASS	POSITION NO	AGENCY
ADVERTISEMENT NO:	GAZZETTE NO:	GAZZETTE DATE:

YOU ARE ADVISED THAT YOUR APPLICATION FOR THE ABOVE POSITION HAS BEEN SUCCESSFUL WITH EFFECT FROM

NOTE:

THIS NOTIFICATION ALSO SERVES AS A NOTICE OF ASSIGNMENT IF THIS POSITION IS IN A PROVINCIAL ADMINISTRATION.

IF YOU FAIL TO TAKE UP THIS APPOINTMENT BY SIX (6) WEEKS FROM THE DATE OF THIS NOTICE, YOU WILL BE DEEMED TO HAVE DECLINED THIS PROMOTION OF TRANSFER.

CHAIRMAN
SELECTION COMMITTEE

DATE:



From RS3.12

PUBLIC SERVICE OF PAPUA NEW GUINEA

Ref:

[]

] NOTIFICATION OF PROMOTION/TRANSFER

REFERENCE	ADVERTISED NO.	GAZETTE NO.	DATE	DEPARTMENT
-----------	----------------	-------------	------	------------

SELECTION COMMITTEE ACTION HAS RESULTED IN THE RE-APPOINTMENT INDICATED BELOW. THE INFORMATION WILL SHORTLY BE ADVERTISED IN THE NATIONAL GAZETTE IN ACCORDANCE WITH SECTION 24(2) (c) (ii) OF THE *PUBLIC SERVICES (MANAGEMENT) ACT* 1995 (as amended).

FULL NAME	PRESENT DEPARTMENT	PROMOTED / REAPPOINTED TO		DATE OF DECISION
		POSITION NO:	DESIGNATION:	

THIS SERVES AS AN ADVICE OFFICIAL NOTIFICATION, WHICH WILL ENABLE YOUR DEPARTMENT TO COMMENCE IMMEDIATELY ANY ACTION WHICH MAY BE NECESSARY OR DESIRABLE AS A RESULT OF THESE CHANGES IN THE STATUS OF THE OFFICER(S) CONCERNED.

IF AN OFFICER IS REQUIRED TO MOVE FROM ONE DEPARTMENT TO ANOTHER AS A RESULT, A CUSTOMARY SIX (6) WEEKS GRACE PERIOD SHOULD BE APPLIED BEFORE HE/SHE IS RELEASED BY HIS/HER ORIGINAL DEPARTMENT AS FROM THE DATE OF THIS NOTIFICATION.

A COPY OF THIS NOTIFICATION WILL ALSO BE FORWARDED TO ANY OTHER DEPARTMENT AFFECTED BY THIS DECISION.

FORWARDED FOR YOUR INFORMATION AND NECESSARY ACTION, PLEASE.

NOTE THAT A PROMOTION OR TRANSFER ONLY TAKES EFFECT FROM THE DATE THAT THE OFFICER COMMENCES DUTY ON TO THIS POSITION.

.....
CHAIRMAN
SELECTION COMMITTEE

.....
DEPARTMENT

.....
DATE



PUBLIC SERVICE OF PAPUA NEW GUINEA

CONDITIONAL OFFER OF EMPLOYMENT

DATE

REFERENCE	ADVERT NO.	NATIONAL GAZETTE NO	DATE	DEPARTMENT
DIVISION		BRANCH/SECTION		LOCATION

DEAR SIR,

THIS SELECTION COMMITTEE WISHES TO INFORM YOU THAT YOUR APPLICATION FOR EMPLOYMENT IN THE ABOVE DEPARTMENT HAS BEEN CONSIDERED AND THE COMMITTEE WISHES TO MAKE YOU A CONDITIONAL OFFER OF EMPLOYMENT AS:

DESIGNATION/CLASSIFICATION:
 POSITION NO.:
 SALARY RANGE:

PLEASE, INDICATE IN WRITING YOUR INTENTION ON THIS CONDITIONAL OFFER OF EMPLOYMENT. SHOULD YOU DECIDE TO ACCEPT THIS CONDITIONAL OFFER, YOU ARE REQUIRED TO PROVIDE TO THIS OFFICE NO LATER THAN 30 DAYS FROM THE DATE OF THIS LETTER THE FOLLOWING:

- (a) MEDICAL CERTIFICATE INDICATING YOUR FITNESS (THE DEPARTMENT WILL MEET THE COST OF MEDICAL EXAMINATION)
- (b) EVIDENCE OF DATE OF BIRTH
- (c) CERTIFIED COPIES OF EDUCATIONAL QUALIFICATIONS
- (d) CHARACTER REFERENCE (FROM A BANK MANAGER, COMMISSIONER OF OATH, A DOCTOR ETC.)
- (e) REFERENCE FROM A CURRENT/PREVIOUS EMPLOYER (IF APPROPRIATE)
- (f) COMPLETED OATH FORM (THIS CAN BE OBTAINED FROM ANY PUBLIC SERVICE DEPARTMENT).

IF THE ABOVE INFORMATION IS NOT RECEIVED WITHIN 30 DAYS OF THIS LETTER, THIS OFFER OR EMPLOYMENT WILL BE WITHDRAWN.

.....
 CHAIRMAN
 SELECTION COMMITTEE

(NOTE: IF ANY OF (a) TO (f) ABOVE HAVE ALREADY BEEN RECEIVED THEN DELETE THEM FROM THE LIST).



PUBLIC SERVICE OF PAPUA NEW GUINEA

APPROVAL TO APPOINT A PROBATION OFFICER

TO: THE DEPARTMENTAL HEAD

REFERENCE NO:

DATE:

REFERENCE	DEPARTMENT	POSITION	DESIGNATION		
CLASSIFICATION	NATIONAL GAZETTE NO.	ADVERTISEMENT NO.	MEDIA	DATE	

A SELECTION COMMITTEE HEARING ON AGREED AND MADE A DECISION TO
SELECT MR/MRS

.....
AS HE/SHE IS SUITABLY QUALIFIED; AND OFFERED HIM/HER A CONDITIONAL OFFER OF EMPLOYMENT.

MR/MRS ACCEPTED THE OFFER AND SUBMITTED ALL INFORMATION (SEE ATTACHED)
REQUIRED FOR SUBMISSION TO THE PUBLIC SERVICE.

IT IS RECOMMENDED THAT MR/MRS BE RECRUITED AS A PROBATIONARY OFFICER TO
THE ABOVE POSITION.

CHAIRMAN
SELECTION COMMITTEE

TO: CHAIRMAN SELECTION COMMITTEE

- APPROVAL TO RECRUIT

APPROVAL IS HEREBY GRANTED/NOT GRANTED FOR THE RECRUITMENT OF MR/MRS
AS PROBATIONARY OFFICER TO THE POSITION OF

SIGNED:
(DEPARTMENTAL HEAD)

DATE:

**CC: THE SECRETARY
DEPARTMENT OF PERSONNEL MANAGEMENT**



PUBLIC SERVICE OF PAPUA NEW GUINEA

Date:

To:

Dear Sir,

SUBJECT: APPOINTMENT TO THE PUBLIC SERVICE

Congratulations! You are hereby appointed as a Probationary Officer in the Public Service. Your salary will commence at the base grade of the salary range for this position.

Designation		Grade	
--------------------	--	--------------	--

Position No		Salary Range (Kina p.a)	
--------------------	--	--------------------------------	--

Please note that you will be on probation for a period of 12 months and that you must apply thereafter to become a Permanent Officer. During this period, an Induction Course and appraisal of your performance will be conducted to assess your eligibility to become a permanent officer.

It would be appreciated if you could contact the HRM Division of this department on phone no..... to confirm when you are available to report for work.

Yours sincerely,

.....
Departmental Head



RECRUITMENT AND SELECTION REPORT

1. **INTRODUCTION**

2. **PURPOSE**

3. **STAFFING AND ESTABLISHMENT**

4. **MODE OF ADVERTISEMENT**

5. **VENUE AND TIME**
 - a. .

6. **COMPOSITION OF SELECTION COMMITTEE**

	Name	Department & Occupation

7. **SELECTION CRITERIA**

The criteria used as basis for short-listing of applicants and final selection hearing are as follow;

- Relevant Qualifications
- Relevant Knowledge and Skills

- Relevant Experience
- Other agreed assessment criteria by the final Selection Committee were;
That preference would be given to acting incumbents unless committee was not satisfied with performance accommodation issue was also taken into account.

8. SUMMARY ON PRE-SELECTION AND SHORTLISTING

9. POSITIONS CONSIDERED

10. Position No:

Applications received and shortlist.

	Name	Justifications
1		
2		
Decision:		

11. SUMMARY /STATISTICS

12. ISSUES AND CONCERNS

13. AFFIRMATIONS

As Technical Advisor to the Selection panel, I affirm that the Selection Committee meeting chaired by <name> has fairly judged the applicants and made decisions in accordance with the Selection Criteria and appointed suitable applicants to carry out the responsibilities of the <agency name>Hospital and rejected those who did not meet the requirements.

.....

.....

Chairperson

Technical Advisor – Selection Committee

Date.....

Date.....

.....

Approved/Not Approved

Department Head

Date.....

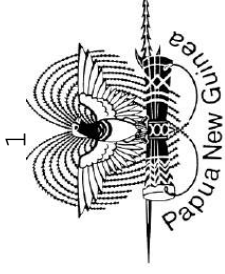

Form RS3.17

PUBLIC SERVICE OF PAPUA NEW GUINEA

ESTABLISHMENT REGISTER – POSITIONAL OCCUPANCY

AGENCY:

DATE:

DPM APPROVED POSITION NO.	DIVISION		BRANCH		SECTION		BUDGET ACTIVITY		
	DESIGNATION	CLASSIFICATION	SUBSTANTIVE OCCUPANT		ACTUAL OCCUPANT		LOCATION	REMARKS	
			NUMBER	NAME	NUMBER	NAME			

(instructions for completion of this are in General Order 3 of the Public Service General Orders)



PUBLIC SERVICE OF PAPUA NEW GUINEA

UNATTACHED OFFICER LIST

DATE:

AGENCY

DIVISION: NUMBER	BRANCH:		CLASSIFICATION	SECTION		BUDGET ACTIVITY:	
	NAME	DESIGNATION		DPM APPROVED POSITION NO.	DATE & REASON FOR ATTACHMENT	DATE & REASON FOR LONG TERM SUSPENSION	OCCUPYING ACTUAL POS.

(instructions for completion of this form are in the National Public Service General Orders)



PUBLIC SERVICE OF PAPUA NEW GUINEA

AGENCY _____ DATE: _____
SHORT/LONG TERM SUSPENSIONS LIST

DIVISION:		BRANCH:		SECTION		BUDGET ACTIVITY:	
NUMBER	NAME	DESIGNATION	CLASSIFICATION	DPM APPROVED POSITION NO.	DATE & REASON FOR ATTACHMENT	DATE & REASON FOR LONG TERM SUSPENSION	OCCUPYING ACTUAL POS.

(instructions for completion of this form are in the National Public Service General Orders)



Independent State of Papua New Guinea
NATIONAL PUBLIC SERVICE
GENERAL ORDERS

**RECOMMENDATION TO THE SECRETARY, MR JOHN M KALI OBE, TO
APPROVE GENERAL ORDER NO. 3 OF 1ST JANUARY 2012**

RECRUITMENT, SELECTION, APPOINTMENT AND STAFF REPORTING

To: Secretary

Date: 08 March 2012

We, the under-signed, confirm that **General Order No. 3 of 1st January 2012**, hereto attached, has been drafted in accordance with Government policies and the appropriate Sections of *Organic Law* the *Public Services (Management) Act*, and the **Regulations** and reflects:

- (a) all policy changes made by the National Executive Council in the period 1st June 2002 to 31st December 2011;
- (b) all changes to the **Constitution**, the *Organic Law on Provincial & Local Level Governments* and the *Public Services (Management) Act 1995*, to effect implementation of the Provincial and Local Level Government Reforms; and,
- (c) all other changes to the *Public Services (Management) Act 1995*, which have been brought into force since 1st June 2002.

On behalf of the Executive Management Team, we recommend that the Secretary authorise this General Order for publication and distribution to line Departments and Agencies.

AGNES FRIDAY
Executive Manager HRAS

ISIKEL MESULAM
Director Legal & Investigations

RAVU VERENAGI
Deputy Secretary, Policy

RAVU VAGI
Deputy Secretary, Operations

